



Evaluate complicated functions. Calculate transcendental functions. Find the roots of: $F(x) = 0$. Find numerical solutions to ordinary differential equations. Invert and multiply matrices. Solve simultaneous equations. Integrate a function between arbitrary limits. Determine best-fit values for statistical samples. Now you can set up calculations like these just once. Record them. Then use them for years.



Texas Instruments SR-52 Handheld programmable calculator

Texas Instruments SR-52. An easy-to-operate programmable calculator with exceptional power.

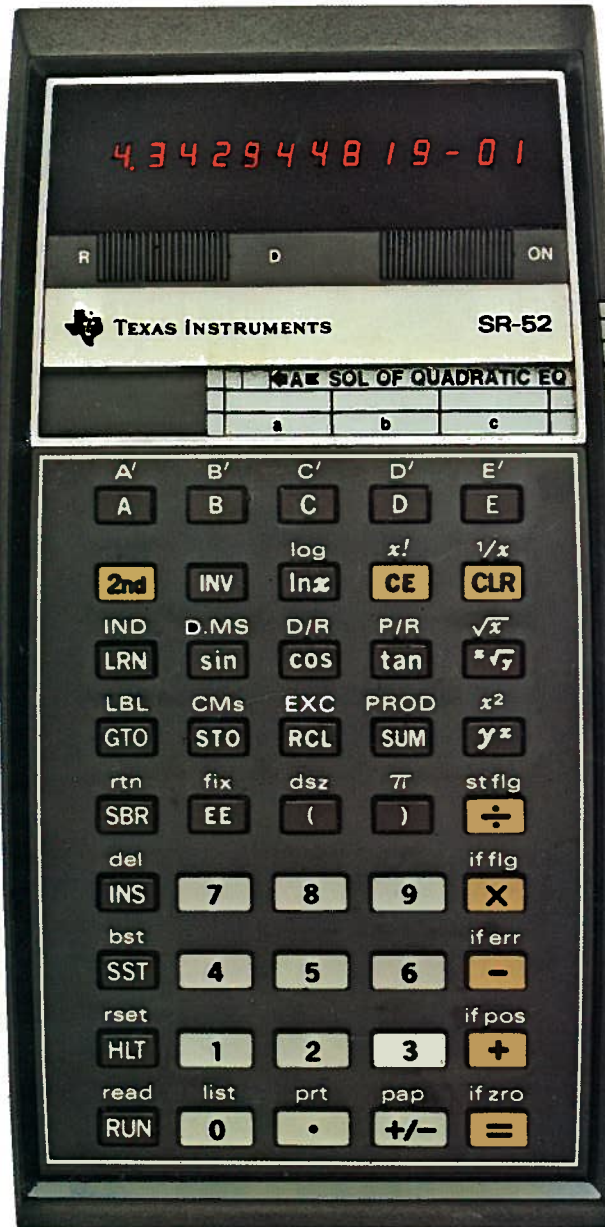

- 224 Program storage locations
- 20 Addressable Memory locations
- 9 Levels of parentheses
- 72 Labels

Now mathematical programming is accessible to any professional. Problems that couldn't be done without waiting to get on a computer are easily handled on an SR-52 weighing little more than 12 ounces.

Complex repetitive problems or lengthy calculations that once took hours can now be solved in seconds. And the chances of error are dramatically reduced.

The SR-52 is actually three calculators in one with three separate modes: Run mode. Calculate mode. Learn mode.

With a few keystrokes, the run mode allows you to quickly solve complex problems with programs from prerecorded magnetic cards. The calculate mode lets you use the SR-52 as a powerful calculator to solve problems manually. And with the learn mode, you can literally teach the SR-52 your unique calculating methods.

All modes can use nine levels of parentheses. 20 independent memory registers and 224 program locations.

Combine this powerful capability with prerecorded programs, or programs you originate yourself, and you have an extremely valuable computational resource right at your fingertips. Exceptional power ... and at an exceptional price.

Run Mode

The SR-52 processes lengthy, complex calculations automatically. And it's not necessary to know about computers or computer language for its programming power to work immediately. Simply select one of the 18 different prerecorded programs from the Basic Library. Or one that you have written.

Load the prerecorded magnetic card. This lets the SR-52 read the card's contents into program memory. Insert the card above the user-defined keys.

Enter known quantities directly into the program. Or into one or more of the 20 addressable memory registers. Or both.

Execution is completely automatic. A program runs until it encounters a halt.

Repeat a program as often as needed. Change values of your known quantities. Solve for different unknowns. The stored program is unaffected.



1. Insert card. Send the A-side of the prerecorded magnetic card through first.

Due to the difficulty of photographing calculator read-outs, displays represented in this brochure are simulated.

(Actual Size)

Combined with its library of programs, it becomes a computational resource of tremendous value.



2. Remove card. And send the magnetic card through again. This time the B-side.



3. Slide the magnetic card into the window. A-side above keys **A** through **E**.

2nd read Read/Write. Lets the SR-52 accept a magnetic card and run a program.
A' through E' Ten User-Defined Keys. Lets you put in your known data. Repeat a program as often as needed. Change values of variables. Solve for different unknowns. The stored program is not affected.

A basic library of prerecorded programs accompanies an SR-52

SOL OF QUADRATIC EQ					BA1-03
a	b	c	n1	n2	

Eighteen prerecorded programs come with an SR-52. And you can put them to work right away. No computer knowledge is necessary. There's no special entry system to learn.

Three diagnostic cards are also supplied to reinforce your program-building confidence.

And you get a 96-page Basic Library Manual. Each program is supported by sample problems, user instructions and program listings.

The Basic Library offers a broad variety of mathematical programs. Programs that will add a new dimension to your problem solving capability.

Conversions 1

Calculates 10 length conversions/inverses, English/metric.

Conversions 2

Calculates 10 conversions/inverses: temperature, weight, volume. English/metric.

Solution of Quadratic Equation

Solves for real and complex roots of basic quadratic equation.

Hyperbolic Functions

Returns values for sinh, cosh, tanh, arc sinh, arc cosh, arc tanh.

Prime Factor Of An Integer

Determines all prime factors of an integer.

Complex Arithmetic

Performs all arithmetic functions for two complex numbers.

Checkbook Balancing

Reconciles checkbook entries with bank statement.

Compound Interest

Solves any one of four variables (PV, FV, I, N) in classical compound interest equation.

Ordinary Annuity 1

Computes any variable in annuity equation when interest rate is known.

Ordinary Annuity 2

Solves for interest rate when other variables are known.

Trend Line Analysis

Determines least-squares fit of data points (x, y) where y is any value and x is integrally incremented beginning with 1.

Permutations and Combinations

Calculates permutation and combinations for a given n and r.

Statistical Means and Moments 1, 2

The arithmetic, geometric, harmonic, and generalized means, the first four moments and the kurtosis and skewness of distribution are calculated for grouped or ungrouped data.

Random Number Generator

Uniformly distributed and normally distributed random numbers are generated.

High Pass Active Filter

Determines component values for high pass active filter.

Low Pass Active Filter

Determines component values for low pass active filter.

Dead Reckoning

Calculates ship's dead reckoning position given last fix and the speed, course, and time interval from last position.

Lunar Landing Game

Simulates a spacecraft's approach to the lunar surface with you at the controls.

Diagnostic 1

Checks for proper operation using five separate subroutines.

Diagnostic 2

Further checks proper operation with five additional subroutines.

Diagnostic 3

Determines proper operation of magnetic card unit.

Optional Libraries

Libraries on a broad range of disciplines are also available: **Statistics**, 25 different programs. **Math**, 31 programs. **Electrical Engineering**, 22 programs. **Finance**, 19 programs. And more are on the way.

Operated manually, the SR-52 is one of the most

Calculate Mode

The calculate, or manual mode is the foundation of the SR-52's programming ease and efficiency. You also use this mode to begin building your own programs. As you work with an SR-52 you will probably discover new dimensions of its flexibility and power—perhaps far more than you initially expected.

Second Function

2nd Second Function. Provides a second use for nearly every key. Increases the power of the calculator without increasing its size.

Inverse Function

INV Used with trig, logs, conversions, sum and product to memories. Fixed point. EE keys.

Data Entry

0 **9** Digit Keys. Enter numbers 0 through 9 to a limit of a 10-digit mantissa and a 2-digit exponent.

. Decimal Point.

2nd **π** Pi. Enters pi to 12 digits. Display indicates value rounded off to 10 digits.

+/- Change Sign. Changes the sign of either the mantissa or the exponent.

Fixed Decimal

2nd **fix** Fixed Decimal. Allows calculated results to be displayed with 0 to 8 decimal places.

Scientific Notation

EE Enter Exponent. Enters subsequent digits as an exponent of 10.

INV **EE** Delete Exponent. Removes scientific notation when not required.

Clear Keys

CE Clear Entry. Clears last entry made with 0 through 9 keys. Also stops flashing display without affecting displayed number.

CLR Clear Key. Clears display and calculation in progress. Does not affect contents of memory registers, flags, counters, program memory, or fixed decimal.

2nd **CMs** Clear Memories. Clears all 20 memory registers.

Arithmetic Operations

+ **-** **X** **÷** Add. Subtract. Multiply. Divide.
= Equals. Completes all pending operations.

Parentheses

(**)** Parentheses. Alter order of processing according to standard algebraic rules. Nine levels possible.

Single Variable Functions

2nd **x^2** Square. Squares number displayed.

2nd **\sqrt{x}** Square Root. Calculates square root of number displayed.

2nd **$1/x$** Reciprocal. Calculates reciprocal of number displayed.

2nd **$x!$** x Factorial. Calculates factorial of integer displayed.

Two Variable Functions

y^x y to the x power.

$\sqrt[y]{x}$ xth root of y.

Logarithmic and Exponential Functions

lnx Natural Logarithm. Determines base e logarithm of displayed number.

INV **lnx** e to the x power. Calculates natural antilogarithm. Raises e to displayed power.

2nd **log** Common Logarithm. Determines base 10 logarithm of displayed number.

INV **2nd** **log** Antilogarithm. Calculates common antilogarithm. Raises 10 to the displayed power.

Direct Memory Register Addressing Keys

STO Store. Stores displayed number into one of the 20 addressable memory registers.

RCL Recall. Displays data stored in a selected register.

2nd **EXC** Exchange. Exchanges contents of a selected register with the displayed number.

SUM Sum. Algebraically sums displayed number to contents of a selected register and retains result.

INV **SUM** Subtract. Subtracts displayed number from contents of a selected register.

2nd **PROD** Product. Multiplies contents of a selected register by the displayed number and retains result in that register.

INV **2nd** **PROD** Divide. Divides contents of a selected register by the displayed number and retains result in that register.

Direct and Indirect Memory Register Addressing

The direct register addressing instruction: 5 **STO** 10, means to store 5 *directly* in register 10, just as shown in the sketch.

Indirect addressing, on the other hand, increases the versatility of all memory registers and allows you to store the address of another memory register for future use.

Indirect Memory Address Keys

Indirect Store. Indirect Recall. Indirect Exchange.

2nd **IND** **STO** Indirect Add. Indirect Subtract. Indirect Multiply. Indirect Divide. Example: the indirect address instruction:

2nd **IND** **RCL** 5 **IND** **STO** 10 means to store 5, not in register 10, but

2nd **IND** **EXC** in the register whose address is found in register 10. Thus, if

2nd **IND** **SUM** 15 were previously stored in register 10,

2nd **IND** **INV** **SUM** then 5 **IND** **STO** 10 would mean store 5 in

2nd **IND** **2nd** **PROD** register 15.

2nd **IND** **INV** **2nd** **PROD** Register 15 has

been indirectly addressed by the given instruction. Diagrammatically here's what happens:

powerful calculators available today.

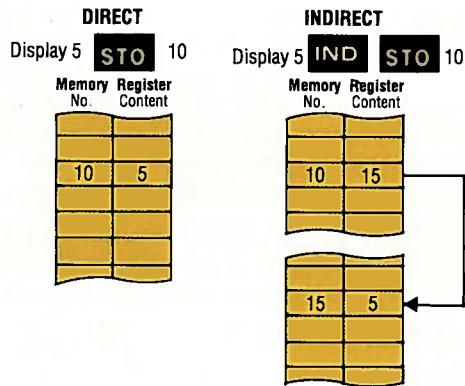

Trigonometric Functions

R **D** Angular Mode Switch. Selects degree or radian mode for trig functions and P/R conversions.

sin Sine. Calculates sine of the angle displayed.

cos Cosine. Calculates cosine of the angle displayed.

tan Tangent. Calculates tangent of the angle displayed.

INV sin Inverse Sine. Calculates \sin^{-1} of the number displayed.

INV cos Inverse Cosine. Calculates \cos^{-1} of the number displayed.

INV tan Inverse Tangent. Calculates \tan^{-1} of the number displayed.

Conversions

2nd D/R Degrees to Radians. Assumes angle displayed is in degrees and converts it to radians (Independent of the Angular Mode switch).

2nd INV D/R Radians to Degrees. Assumes angle displayed is in radians and converts it to degrees (Independent of the Angular Mode switch).

2nd D.MS Degrees/Minutes/Seconds to Decimal Degrees. Converts the number displayed from degrees/minutes/seconds to decimal degrees.

INV 2nd D.MS Decimal Degrees to Degrees/Minutes/Seconds. Converts

the number displayed from decimal degrees to degrees/minutes/seconds.

2nd P/R Polar to Rectangular. Converts as follows: r **STO** 00, θ **2nd P/R** \Rightarrow y , **RCL** 00 $\Rightarrow x$.

INV 2nd P/R Rectangular to Polar. Converts as follows: x **STO** 00, y **INV 2nd P/R** $\Rightarrow \theta$, **RCL** 00 $\Rightarrow r$.

Display

Power-on and numerical information. Provides indication of a negative number, decimal point, overflow, underflow and error. Displays 10-digit mantissa and 2-digit exponent.



Overflow & Underflow Indications

Display flashes when number entered or calculation result is larger than $\pm 9.999999999 \times 10^{99}$ and when number entered or calculation is closer to zero than $\pm 1. \times 10^{-99}$. Display also flashes to indicate certain error conditions.

Fast Rechargeable Battery Pack

Provides up to 5 hours operation without recharging. Recharging for about 4 hours restores full charge.

Size

Length 6.44 in. (16.36 cm). Maximum width 3.31 in. (8.41 cm). Maximum thickness 1.70 in. (4.32 cm).

Weight

12.3 ounces (348.7 grams).

Algebraic entry vs Reverse Polish Notation

A candid comment

Most handheld scientific calculators use either algebraic entry or reverse Polish notation (RPN). There are two basic schools of thought on which is best—each manufacturer advocating his own.

And, to make it more confusing, a good case can be made for both by the careful selection of sample problems. In truth, there is no ultimate answer. Either system can be operated with ease by the experienced owner. And either can be a boon to the simple solution of the most complex problems. Many practiced users of RPN now swear by it. But owners of algebraic machines can find RPN awkward and confusing. It boils down to individual preference.

The case for algebraic is straightforward: It lets you key the problem just as you would state it. Because it works the way you think, most people find it easier to master and more natural to use. That's why TI and most other manufacturers chose this method. For example, when we think in algebraic notation, we say, "Two times four equals eight". With RPN, we'd have to say, "Two and four multiplied". An oversimplification, but it points up the fundamental difference.

This is the way it's done on the SR-52—easy left-to-right entry. You enter calculations exactly as you write them. The SR-52 combines a 3-level algebraic hierarchy with 9 levels of parentheses. This lets you enter problems containing up to 10 pending operations (three times the capability of the only other machine in its class). This means you don't have to presolve the problem or search for the most appropriate, efficient order of execution. The SR-52 does this automatically.

To demonstrate, try this problem. Enter it just as it's written:

$$10 - 5 \div (4 + 8 \div 3 + 2) =$$

the answer is 9.423076923

Enter this problem left-to-right using RPN and you'll get a totally different answer.

If you evaluate the alternatives, we think you'll prefer algebraic entry. But even if you are already conditioned to RPN, the added value offered by the SR-52 is well worth the easy transition.

Teach the SR-52 your personal approach to pr

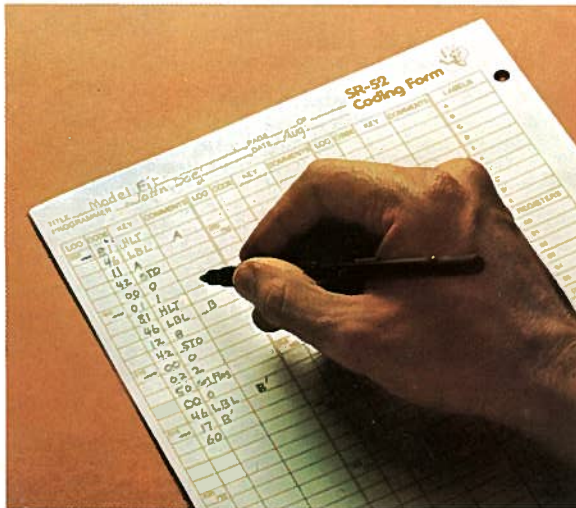

Use the Coding Form (it comes with the SR-52) and make a list of the keystrokes needed to solve your problem.

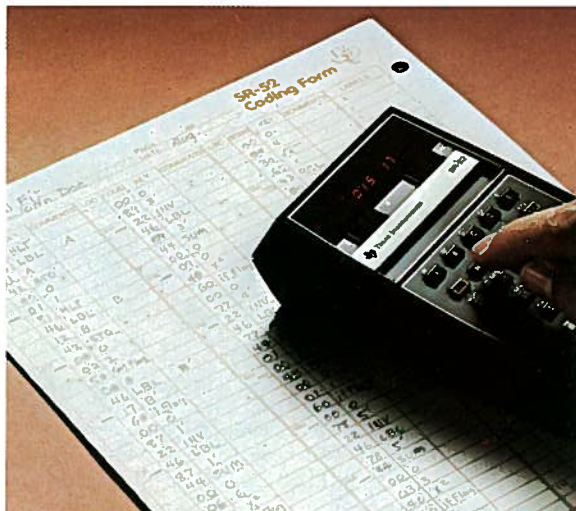

Set the SR-52 in the learn mode using your Coding Form as a ready reference to key in the steps leading to the solution of your problem.

Learn Mode

Simply key-in your problem left-to-right as you would in the calculate mode. You can construct a program of up to 224 steps (000 to 223) and store it in the program memory.

Program Memory Location	Your Number, Function or Decision/Transfer
000	2nd LBL
001	A
002	RCL
221	6
222	=
223	HLT

LRN Learn. Puts the SR-52 in and out of learn mode.

2nd LBL Label. Saves the code of the next pressed key as a non-executable label, thus naming a program segment. Up to 72 are available by using first and second level keys including the **2nd** key with **0** through **9**.

A B C D E 2nd A' B' C' D' E' User-Defined Keys. These 10 keys become any function the user wants them to be.

Program Transfer Statements or Branching

Program steps are usually processed as they're entered. But often clusters of steps need to be handled out of sequential order. This skipping around is called branching or transferring. There are two types:

Unconditional Transfers

Tells the SR-52 to skip to another part of the program regardless of what has taken place or is taking place as shown in the sketch. Involves the go to **GTO** instruction. The subroutine call **SBR**. And the user-defined keys **A** through **E** and **A'** through **E'**.

Unconditional Transfers

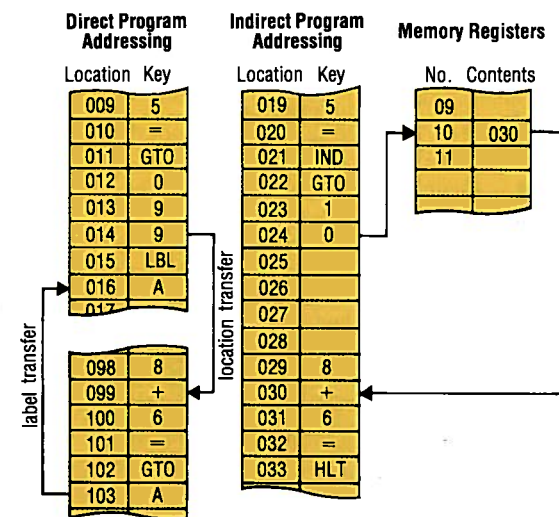

Edit and Debug

Lets you trial-run your program. Move through a program a step at a time, forward or backward. Add more steps. Delete. Or write over steps. Then record.

SST Single Step. Permits single stepping through a program in the learn mode.

Also used in the calculate mode to execute a program one step at a time.

2nd bst Back Step. Single steps backward through a program in the learn mode.

2nd del Delete. Removes displayed instruction and automatically shifts following instructions up when in the learn mode.

INS Insert. Moves the current and all following instructions down one location when in the learn mode.

Problem solving. And record it on a magnetic card...

Unconditional Transfer Keys

- GTO** Go To. A prefix key. Moves program counter to a new program location, defined either by a 3-digit program location or a label.
- SBR** Subroutine. A prefix key. Used with either a label or a 3-digit program location. Causes a transfer to a program segment to be used as a subroutine.
- 2nd IND GTO** Indirect Go To. Transfers to the location in program memory specified by the contents of a memory register.
- 2nd IND SBR** Indirect Subroutine. Transfers control to a program segment designated as a subroutine whose starting location is found in the specified memory register.

Conditional Transfers

These statements depend on tests. If test conditions are met, then transfer or branch takes place. Otherwise the regular sequence continues, see sketch. Three types of tests are conducted: The display (positive, negative, zero, flashing, not flashing). Flags (set, not set). Contents of register 00 (zero or not zero).

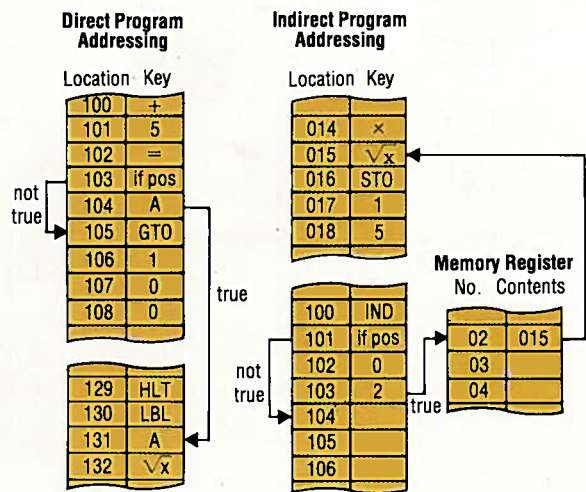

Conditional Transfer Keys

- 2nd if pos** If Positive. Tests display register for positive or zero. If it is, transfer occurs to a location or label. If the test fails, transfer does not occur.
- 2nd if zro** If Zero. Tests display register for zero. If it is, transfer occurs to a location or label. If not, no transfer.
- 2nd if err** If Error. Tests for an error condition (flashing display). If it is, transfer occurs to a location or label. If not, no transfer.
- 2nd dsz** Decrement and Skip on Zero. Decrements the contents of memory register 00, then tests these contents for zero. If it is not zero, transfer occurs to a location or label. If it is, no transfer.

Inverse Conditional Transfer Keys

Reverses all the above conditional transfers. For example, **INV 2nd if pos** tests the display and causes a transfer when the display is negative.

Flags

Flags are signals. The SR-52 has five. Each is set or reset by you. Manually from the keyboard, or as part of a stored program. The flag's condition can be tested by the **if flg** transfer instruction.

Let's use an analogy. You're a train dispatcher in a switch tower. A train is going down the track. It encounters a signal at a junction. If the signal is raised the train goes to San Francisco. If the signal is lowered it goes to New York. As a dispatcher, you must raise or lower the signal which, in turn, controls which branch the train takes. Likewise, on the SR-52 you can manually control program options directly from the keyboard before execution.

MANUAL FLAG OPERATION

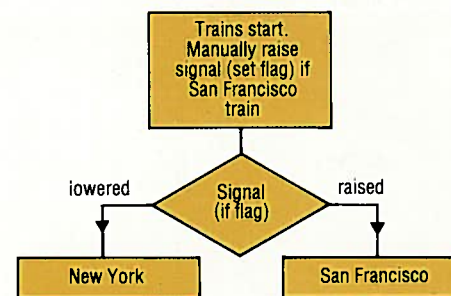

In another situation, the trains themselves can set the signals. Therefore, as dispatcher, you only monitor which tracks are being used. Similarly, on the SR-52, you can have the program automatically set the flag based on data. And the program tests the flag's condition to automatically guide the program to the correct conclusion.

AUTOMATIC FLAG OPERATION

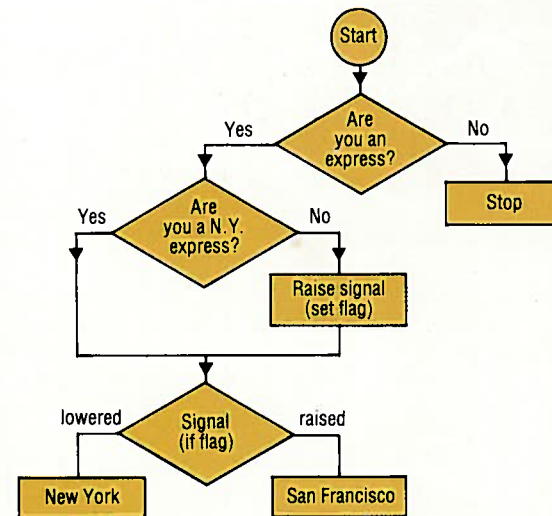

Flag Keys

- 2nd st flg** Set Flag. Sets one of the flags, 0 through 4. For example, **2nd st flg 3** means set flag number 3.

INV
 2nd
 th
 oc
 pr
 se
 INV
 no
 la
 I
 fe
 Indirect
 with Co
 2nd
 2nd
 2nd
 2nd
 2nd
 2nd
 contents
 get the t
 Since a tr
 can add t
 the locati
 Program
 2nd
 2nd
 HLT

it on a magnetic card...to use again and again.

gister for transfer test fails, ister for to a loca- condition transfer transfer. o. Decry- rry regis- zero. If it cation or

fers. For play and e.

is set or or as part be tested

atcher in track. It signal is e signal is cher, you , controls the SR-52 s directly

MANUAL FLAG OPERATION

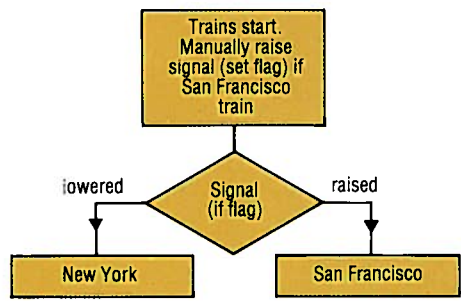

In another situation, the trains themselves can set the signals. Therefore, as dispatcher, you only monitor which tracks are being used. Similarly, on the SR-52, you can have the program automatically set the flag based on data. And the program tests the flag's condition to automatically guide the program to the correct conclusion.

AUTOMATIC FLAG OPERATION

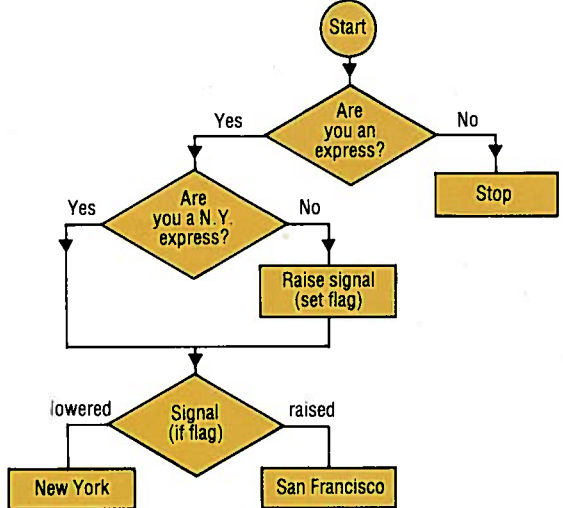

Flag Keys

2nd **st flg** Set Flag. Sets one of the flags, 0 through 4. For example, **2nd** **st flg** **3** means set flag number 3.

INV **2nd** **st flg** Reset Flag. Lowers or clears specified flag.

2nd **if flg** If Flag. Tests to see if specified flag is set. If it is, then transfer occurs to the location or label. If flag is reset, no transfer occurs. For example, **2nd** **if flg** **3** **0** **1** **1** means if flag is set, transfer to program location 011. Or, **2nd** **if flg** **3** **A** means if flag 3 is set, transfer to that segment of the program labeled A.

INV **2nd** **if flg** Test Flag. Tests to see if specified flag is set. If it is not, then transfer occurs to the location or label. If it is, no transfer. For example,

INV **2nd** **if flg** **3** **A** means transfer to A if flag 3 is reset.

Indirect Program Addressing with Conditional Transfer Keys

2nd **IND** **2nd** **if pos** Transfer addresses are specified indirectly by preceding the normal key sequence with **2nd** **IND** **2nd** **if zro** **2nd** **IND** **2nd** **if err** **2nd** **IND** and by replacing the 3-digit program location or label with a 2-digit memory register address. For example,

2nd **IND** **2nd** **if pos** **0** **2** means if the contents of the display register is positive, then get the transfer location from memory register 02. Since a transfer location is in a memory register, you can add to, subtract from, multiply by, or divide into the location numbers.

Program Memory Control Keys

2nd **rtn** Return. Ends a program segment which defines a subroutine and returns control to the point of the call.

2nd **rset** Reset. Resets the program counter to location 000 and resets all flags.

HLT Halt. Stops program execution and returns control to keyboard.

Record Program Keys

2nd **read** Read/Write. Reads a program from a card into program memory.

INV **2nd** **read** Inverse Read/Write. Writes (records) a program on the magnetic card from program memory.

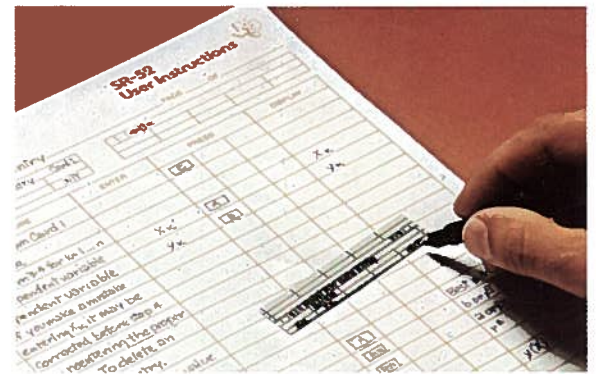

After you've completed your program you can store it. And record it. Permanently, by running a magnetic card through the reader. Now it's in the SR-52 and on your card.



After the card is labeled it is available at your fingertips for repetitive problem solving. Simply insert the card and operate the SR-52 in the run mode. You save time and effort, and have greatly reduced the chance of error since there are far fewer steps to perform.

Problem solving.

Unconditional Transfer Keys

GTO Go To. A prefix key. Moves program counter to a new program location, defined either by a 3-digit program location or a label.

SBR Subroutine. A prefix key. Used with either a label or a 3-digit program location. Causes a transfer to a program segment to be used as a subroutine.

2nd **IND** **GTO** Indirect Go To. Transfers to the location in program memory specified by the contents of a memory register.

2nd **IND** **SBR** Indirect Subroutine. Transfers control to a program segment designated as a subroutine whose starting location is found in the specified memory register.

Conditional Transfers

These statements depend on tests. If test conditions are met, then transfer or branch takes place. Otherwise the regular sequence continues, see sketch. Three types of tests are conducted: The display (positive, negative, zero, flashing, not flashing). Flags (set, not set). Contents of register 00 (zero or not zero).

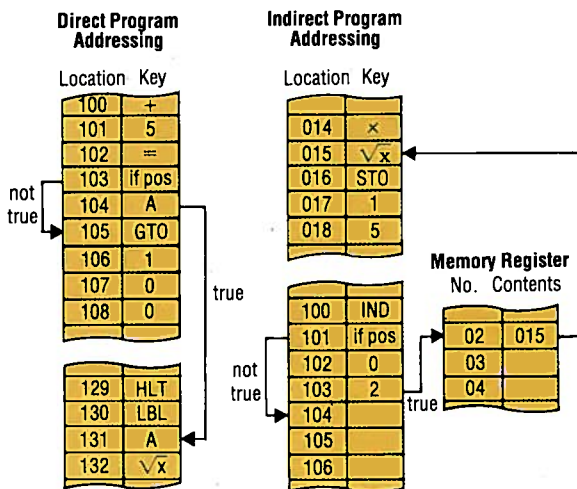

Compare the new SR-52 with the HP-65

Programming Capability

	SR-52	HP-65
Program steps	224	100
Merged prefixes	all merged	Stack and comparison
Merged store and recall instruction codes	no	yes
Program read/write	yes	yes
User-defined function keys	10	5
Possible labels	72	15
Absolute addressing	yes	no
Subroutine capability	yes	yes
Subroutine levels	2	1
Program flags	5	2
Unconditional branching	yes	yes
Conditional branching decisions	10	7
Indirect branching	yes	no
Editing		
single-step	yes	yes
back-step	yes	no
insert	yes	yes
delete	yes	yes
Single-step program execution	yes	yes
Optional lock-in printer*	yes	no

*Available early 1976.

Calculating Capability

	SR-52	HP-65
Log, ln _x	yes	yes
10 ^x , e ^x	yes	yes
x ²	yes	yes
√x	yes	yes
∛y	yes	no
y ^x	yes	yes
1/x	yes	yes
x!	yes	yes
Trig (sin, cos, tan and inverses)	yes	yes
Degrees-minutes-seconds to decimal degrees conversion	yes	yes
Degree, minute, second arithmetic (+, -)	no	yes
Degree/radian conversion key	yes	no
Polar/rectangular conversion	yes	yes
Octal conversion	no	yes
Absolute value	no	yes
Integer, fraction part	no	yes
Built-in π value precision	12 digits	10 digits

Operating Characteristics

	SR-52	HP-65
Angular modes	2	3
Fixed-decimal option	yes	yes
Calculating digits	12	10
Digits displayed (mantissa + exponent)	10 + 2	10 + 2
Data memories	20	9
Memory arithmetic (+, -, ×, ÷)	yes	yes
Exchange x with y	no	yes
Exchange x with data memory	yes	no
Entry mode	full algebraic	RPN
Max. number of pending operations handled	10	3
Number of keys	45	35
Indirect memory addressing	yes	no

The technological achievement beneath the keyboard is the reason the SR-52 offers so much programming value.

A full-function scientific calculator is a state-of-the-art product reflecting state-of-the-art technologies. It's logical, then, to look first to the manufacturer known worldwide for both — Texas Instruments.

TI has long been a leader in solid-state technology and has pioneered a series of landmark developments relating directly to calculators: The original integrated circuit. Key patents in basic MOS/LSI technology. The "calculator-on-a-chip" integrated circuit which became the heart of miniature calculators. And the basic patent on the miniature calculator itself.

TI is steeped in calculator technologies from start to finish, making all critical parts and controlling quality every step of the way. And that's the key to the exceptional quality and value of the SR-52.

Texas Instruments SR-52. Unmatched capability and value. With a wide range of software and helpful accessories. See and test an SR-52 for yourself.



The SR-52 comes equipped with customized software: A 36-page Operating Guide for quick reference to keystrokes and basic operations. A 208-page Owner's Manual for comprehensive, detailed information with numerous examples. A 96-page Basic Library Program Manual shows you how to use your prerecorded programs. 18 prerecorded program cards which you can put to work immediately. 3 diagnostic cards let you check for programming accuracy. A head cleaner to remove oxides and foreign particles from the magnetic read/write head. 20 blank magnetic cards let you develop your own programs. A carrying case for pre-programmed and prerecorded cards. A 50-sheet tablet of User Instructions and Coding Forms makes your own special programs easy to build. An AC adapter/charger to use while operating or for fast battery recharge from 115 V/60 Hz wall outlet. And a sturdy vinyl, cushioned carrying case with pockets for the Operating Guide and program card case.

And soon to be available... An optional desktop lock-in printer... The PC-100*

Soon you'll be able to plug your SR-52 into a PC-100 printing unit and get a tape copy of your calculations fast. And it provides lock-on security as well as power.

The PC-100 also prints instructions or results without halting program execution, and can trace step by step.

With a PC-100 you'll be able to verify that keyed-in instructions match those on your Coding Form. You'll have quick program documentation for ready reference. You'll have the means to verify that a program was based on correct formulation.

*Available early 1976



Keys that Print Your Calculations

- 2nd list** Prints out an entire program.
- 2nd prt** Prints calculate mode results.
- 2nd pap** Advances paper.

If you would like the name of a retailer carrying the SR-52 near you, call Consumer Relations toll free: (800) 527-4980. In Texas call (800) 492-4298.

TEXAS INSTRUMENTS
INCORPORATED